

Hebei Shida Seal Group

IATF 16949:2016 Registered Manufacturer



Honesty · Integrity · Professionalism

About Us

A Professional Manufacturer From Qinghe, Hebei, China. Our Goal Is To Supply High-Quality Rubber Parts At Cost-effective Prices On Time, Every Time.

1 Automotive Weatherstrips

2 Custom Extruded Rubber Products

3 Custom Molded Rubber Products



Facts & Figures

In Operation since 2000, Hebei Shida Seal Group Has Grown To Be A Leading Source Of Automotive Sealing Products For Customers Worldwide.

1 Company Name:

Hebei Shida Seal Group Co., Ltd.

2 Business Type / Legal Form:

Limited Liability Company

3 Founder & Legal Representative:

Mr. Song

4 Registration:

Qinghe County Administration for Industry & Commerce issued Enterprise Corporation Business License to Hebei Shida Seal Group Co., Ltd. in 2000 with valid period from 2000 to 2030.

5 Date of Registration:

December 12, 2000

6 Unified Social Credit Code:

91130534601185223E

7 Registered Capital:

CN ¥ 58 million (US \$ 8.96 Million)

8 Annual Income:

CN ¥ 150 million (US \$ 23.2 Million)

Facts & Figures

In Operation since 2000, Hebei Shida Seal Group Has Grown To Be A Leading Source Of Automotive Sealing Products For Customers Worldwide.

9 Line of Business:

The company is mainly engaged in production and sale of weatherstrips, rubber seals, molded rubber components, rubber & plastic products, control cables, filters, metal stamped parts, parts for automotive door and window, rail vehicles, aviation equipment, boats and ships; sale of chemical raw materials (hazardous chemicals excluded) ; export or import of goods and technology(items prohibited by laws, regulations or the State Council excluded).

10 Facility Size:

40,000 m²(430,556 ft²)

11 Employment:

320

12 Quality Certificate:

IATF16949:2016

13 Primary SIC Code:

(3061) Molded, Extruded, and Lathe-Cut Mechanical Rubber Goods

14 Primary NAICS Code:

(326291) Rubber Product Manufacturing for Mechanical Use

15 CAGE / NCAGE Code:

SBAD5

Research and Development (R&D)

Hebei Shida Seal Group is committed to providing its customers with the best sealing products, resulting from intense research and development efforts. We maintain close partnerships with leading vehicle manufacturers (OEM's), material suppliers, institutes, universities and other companies to strengthen R&D activities and explore new materials and new processes. We have a team of experienced engineers who excel in all phases from product design, manufacturing process design, product test, quality management system to creative manufacturing equipment design, and can undertake entire product development programs (automotive weatherstrips and seals including door seals - door and body mounted, glassruns, hood seals, trunk/decklid seals, door belts, etc.

Our highly qualified employees with excellent skills, abilities, and performance form the foundation of high-quality products we take pride in. We guarantee all products are manufactured meeting strictest technical specifications and requirements.



Simulation and Analysis Of Polymer Flow In Extruder

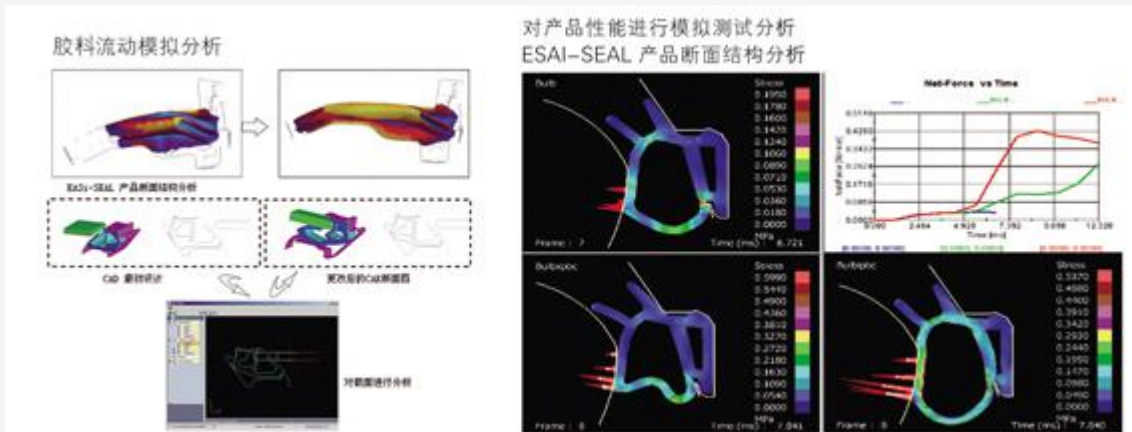

Research and Development (R&D)

Hebei Shida Seal Group designs and manufactures custom-made rubber seals for customers in the automotive industry as well as a variety of markets, utilizing software tools such as Catia, Solidworks, Autodesk, etc.

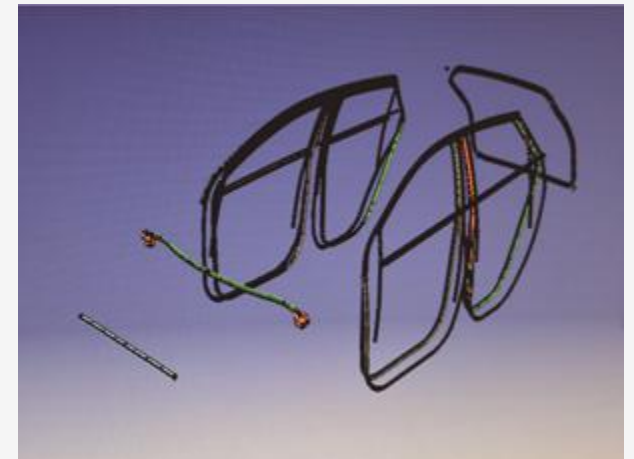
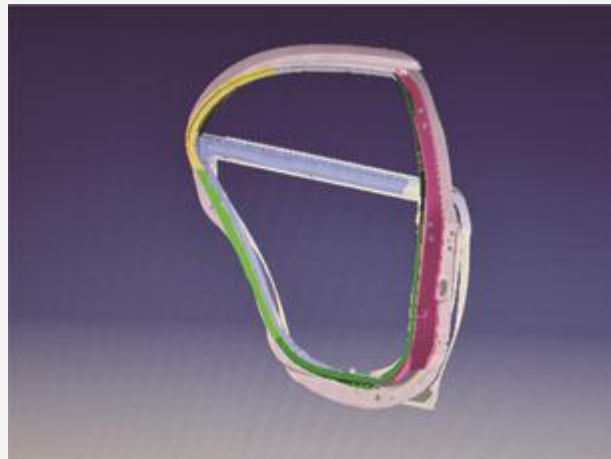
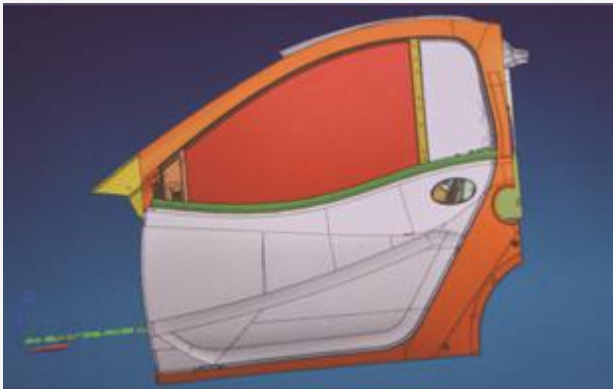
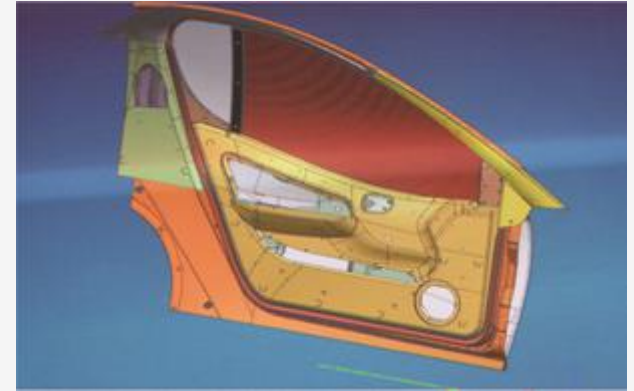

Capabilities

Hebei Shida Seal Group has an unparalleled range of capabilities including extrusion, co-extrusion, compression molding, injection molding and finishing capabilities and we can process a wide range of elastomeric materials: EPDM rubber, nitrile rubber, neoprene rubber, silicone rubber and thermoplastic vulcanizates.



Mixing
Capabilities



Extrusion
Capabilities



Molding
Capabilities



Secondary
Operations

Capabilities - Mixing

Hebei Shida Seal Group manufactures high-quality rubber parts which require compounds that meet exacting standards for performance and we have the ability to develop special and specific formulations for customers' applications. Our custom rubber mixing and formulating capabilities include compound development, internal mixing and open mill mixing of black or colored compounds (strips, slabs, and calendared). Our state-of-the-art mixing facility is equipped with 1 internal mixer (dispersion kneader), and 3 open mills dedicated to the mixing of EPDM. Custom mixed rubber compounds are used for rubber extrusions and molded rubber products.



Raw Materials Warehouse



Formulating



Mixing



Rubber Compound

A two-stage (two-pass) mixing process:

- ◆ **Stage A: CMB (Carbon Master Batch) production** - Mix rubber polymer, non-vulcanizing ingredients like carbon black, silica, softener, plasticizer and process oil physically in the internal mixer.
- ◆ **Stage B: FMB (Finish Master Batch) production** - After Stage A mixing has been completed and time for cooling has been allowed, Stage B mixing is carried out in which curatives (vulcanizing agents) like sulfur, accelerators, peroxides into CMB(Carbon Master Batch).

Capabilities - Extrusion

At Hebei Shida Seal Group, we specialize in extruded rubber products of many materials, profiles and sizes. Our facility has 4 Continuous Vulcanization (CV) extrusion lines (microwave curing/vulcanization + hot air curing/vulcanization) and 1 Thermoplastic Vulcanizate (TPV) extrusion line with full in-line printing capabilities. With combined experience within the industry, we have developed the talent, technical knowledge, engineering expertise and equipment to manufacture rubber and plastic extrusions meeting the most stringent specifications.

We have established ourselves in automotive industry and became a preferred supplier of body seals and weatherstrips.

Rubber extrusions engineered to your specifications:

- ✓ Custom Rubber Extrusions and Profiles
- ✓ Automotive Weatherstripping, Door Seals, Window Seals
- ✓ Edge Trims & Seals, Self-Sealing Weatherstrips
- ✓ Window Channels, Flocking and Urethane Slip-coating
- ✓ EPDM Dense and Sponge Rubber
- ✓ Engineered TPV/TPE Profiles
- ✓ Co-extruding (dual durometers with a Metal Core, Segmented Steel or Wire Carrier)



Capabilities - Molding

At Hebei Shida Seal Group, we specialize in a complete line of molded rubber products, which meet stringent quality and technical specifications. We can produce custom molded rubber parts through a variety of processes, including rubber compression molding, rubber injection molding, and plastic injection molding, as well as rubber-to-metal bonding. We proudly maintain a modern manufacturing facility which has state-of-the-art rubber vulcanizing presses (40 sets) and rubber injection molding machines (20 sets) to meet the various needs of customers for in a variety of market segments.

Rubber Molding Materials (Compounds):

- ✓ EPDM(Ethylene Propylene Diene Monomer)
- ✓ NBR (Nitrile, Buna-N)
- ✓ Silicone
- ✓ Custom color compounds (color matching)

Customized Rubber Products

- ✓ Wiring Harness Rubber Grommets
- ✓ Automotive Rubber Bellows and Boots
- ✓ Air Intake Hoses, Ducts
- ✓ Molded Rubber Pedals and Pedal Pads



Capabilities - Secondary Operations

At Hebei Shida Seal Group, we offer a variety of integrated capabilities and technologies, and our secondary operations and additional services to customized microwave cured rubber extrusions, extruded rubber and plastic profiles, weather-stripping, trims and seals, include, but are not limited to flocking, urethane slip-coating, splicing, molded corners (joints), PSA (Pressure Sensitive Adhesives) tape backing, in-line cutting, drilling, notching, punching, printing, custom color matching, private label packaging, etc.



Ventilation Holes



Molded Corners



PSA Taping



Retainers (Plastic Clips)

Quality Management - Physical Testing

At Hebei Shida Seal Group, our physical testing laboratory conducts physical / mechanical analysis of rubber and polymeric materials and testing of finished goods such as automotive sealing products, industrial rubber seals, rubber extrusions, profiles, and molded rubber parts, etc. This testing laboratory offers a full range of physical / mechanical testing services to evaluate rubber materials or components like hardness, tensile strength, compression set, tension set, elongation at break, adhesion, abrasion, aging in hot air and performance tests.



Typical Rubber Testing Equipment:

- ✓ Moving Die Rheometer
- ✓ Mooney Viscometer
- ✓ Tensile Strength Tester
- ✓ Aging Oven
- ✓ Flock / Coating Abrasion Resistance Tester

Quality Management - Chemical Testing

At Hebei Shida Seal Group, our chemical testing laboratory conducts chemical / material analysis of rubber and polymeric materials used for manufacturing automotive sealing products, industrial rubber seals, rubber extrusions, profiles, and molded rubber parts, etc. This testing laboratory offers a full range of chemical / material analysis services to evaluate rubber materials, and we perform tests utilizing a wide range of analytical methods, which enable us to accurately identify materials.

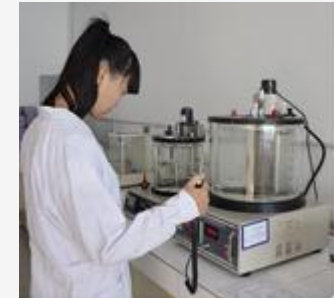

Typical Rubber Testing Equipment:

- ✓ Tester for Oil Aniline Point Determination
- ✓ Viscometer for Kinematic Viscosity Determination
- ✓ Digital Analytical Balance (0.0001g Accuracy)
- ✓ Electro-thermal Constant-temperature Drying Oven

Quality Management – IATF 16949 Registered

Hebei Shida Seal Group is certified by NQA (National Quality Assurance), and has received certificate for our quality management system – a system that meets the requirements of the IATF 16949 standards. The IATF 16949 certification is a guarantee that we can Design and Manufacture rubber weatherstrips, extruded rubber products, and molded rubber products that fulfill the requirements specified by the IATF and the automotive industry.

Quality is vital to our business success and is a critical part of our employee training and professional development. Our quality management system is focused on excellence from incoming inspection of raw materials, inspection of work-in-process to the final audit of outgoing products.



We ensure that quality is built into every step of the manufacturing process and use quality standards such as APQP, FMEA and PPAP to ensure that products are launched successfully and designed to prevent defects.

We strive to meet or exceed customer requirements and expectations while ensuring continuous improvement of our products, processes and people.



Markets

Our diversified sealing products, extruded and molded rubber products are used in virtually every industry. We are here to help you solve your problems.

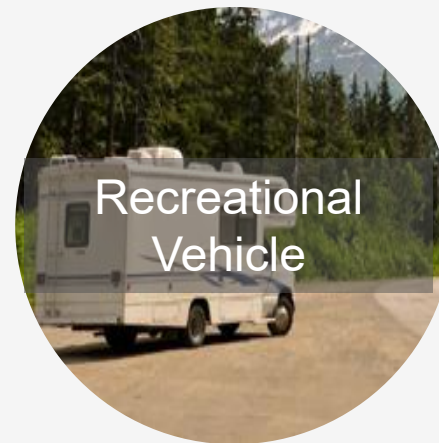

Automotive Weatherstrips - Door Seals

Hebei Shida Seal Group manufactures a broad range of automotive body sealing products that protect the vehicle interior from dirt, noise and rainwater. As a reputable manufacturer specializing in weather-stripping for automotive door, window, trunk and hood applications, we have developed strong business relationships with some of the leading OEM's and Tier-1 suppliers.



Door Weatherstrips

Door Weatherstrips are attached to vehicle door with self-adhesive tape or plastic retaining clips and acts as the first sealing barrier between vehicle door and body, preventing various outside elements like water, air, dust and noise from entering the vehicle cabin. Door weatherstrips (primary door seal) are used together with opening trim weatherstrips (secondary door seal) to achieve better performance.



Door Opening Trim Weatherstrips

Door Opening Trim Weatherstrips fit into vehicle body panel and plays a major role in isolating the vehicle cabin from outside water, air, dust and noise. Opening Trim Weatherstrips also buffer impacts from the opening and closing of door and ensures easy closing and better sealing effect. The rubber seals are often coated with colored EPDM rubber which has the same pattern with vehicle interior to provide elegant appearance.

Automotive Weatherstrips - Glass Seals

Hebei Shida Seal Group manufactures a broad range of automotive body sealing products that protect the vehicle interior from dirt, noise and rainwater. As a reputable manufacturer specializing in weather-stripping for automotive door, window, trunk and hood applications, we have developed strong business relationships with some of the leading OEM's and Tier-1 suppliers.



Door Glass Runs

Door Glass Runs are mounted to insides of the automotive door window frame and enable movable window glass to slide freely, and also stabilizes the glass during glass movement and door closing. The rubber channel is covered by flock or coated with abrasion resistance polyurethane(PU) coating to minimize friction during movement of the glass.



Inner Belts and Outer Belts

Door Inner Belts and Outer Belts are mounted along the beltline of vehicle door preventing outside weather elements from entering vehicle compartment, and also stabilize the window glass during its movement. Beltline weatherstrips have flocked surfaces which help reduce friction and noise. The material is usually PVC and metal

Automotive Weatherstrips - Window and Liftgate Seals

Hebei Shida Seal Group manufactures a broad range of automotive body sealing products that protect the vehicle interior from dirt, noise and rainwater. As a reputable manufacturer specializing in weather-stripping for automotive door, window, trunk and hood applications, we have developed strong business relationships with some of the leading OEM's and Tier-1 suppliers.



Windshield and Rear Window Weatherstrip

The **Windshield / Rear Window Weatherstrip** surrounds the windshield / rear window glass and keep it in place. Windshield / rear window weatherstrips prevent air, water, dust and noise from entering insides of vehicle cabin.



Luggage Compartment Weatherstrips

Luggage Compartment Weatherstrips (Liftgate seals, trunk seals, deck lid seals) fit into vehicle body panel around the trunk and prevents air, water and debris from entering the trunk compartment.

Standard Weatherstrips & Seals - Door Glass Runs / Glass Run Channel

Hebei Shida Seal Group manufactures door glass runs, flocked or coated glass run channels automotive industry as well as other markets. We offer extruded profiles of various shapes and sizes. The mostly used material is EPDM rubber, and our custom EPDM rubber compound features very good compression set, high tensile strength, excellent weathering, ozone, UV, water, steam, high and low temperature resistance.

Types of Glass Run Channels:	
1. Flocked Glass Run Channel	Material: EPDM Dense Rubber + Nylon Fibers or Polyester Fibers
2. Coated Glass Run Channel	Material: EPDM Dense Rubber + Polyurethane(PU) Coating
3. Hybrid Profile Glass Run Channel	Material: EPDM Dense Rubber + TPE Slip-coating
4. TPV Glass Run Channel	Material: Thermoplastic Vulcanizate(TPV) + Low-friction Coating

Standard Weatherstrips - Door Glass Runs / Flocked

Hebei Shida Seal Group manufactures door glass runs, flocked or coated glass run channels automotive industry as well as other markets. We offer extruded profiles of various shapes and sizes. The mostly used material is EPDM rubber, and our custom EPDM rubber compound features very good compression set, high tensile strength, excellent weathering, ozone, UV, water, steam, high and low temperature resistance.

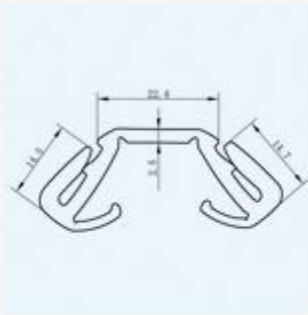

SDQC-001

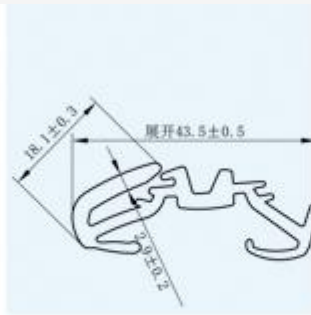

SDQC-002



SDQC-003

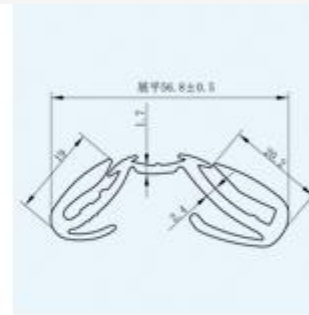

SDQC-004



SDQC-005

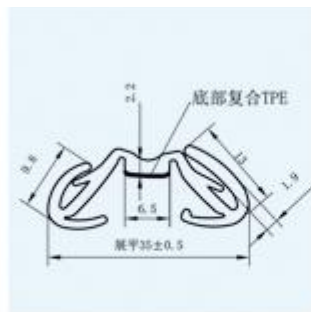

SDQC-006

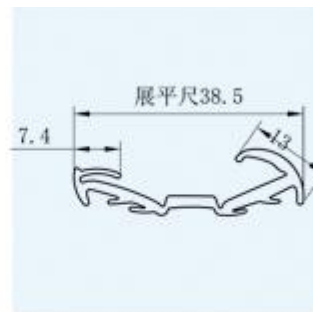

SDQC-007

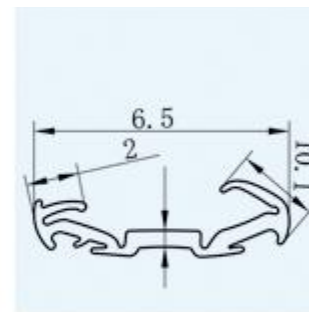

SDQC-008

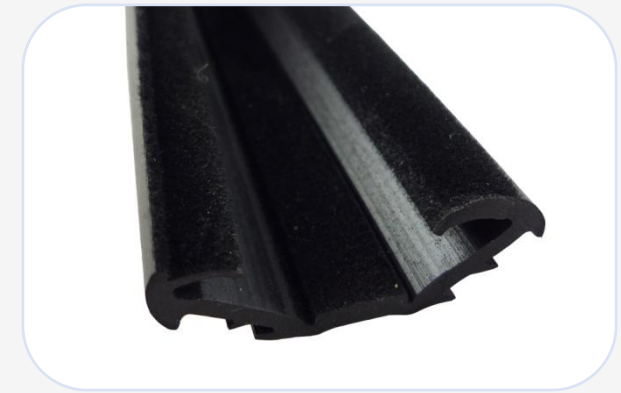

Standard Weatherstrips - Door Glass Runs / Coated

Hebei Shida Seal Group manufactures door glass runs, flocked or coated glass run channels automotive industry as well as other markets. We offer extruded profiles of various shapes and sizes. The mostly used material is EPDM rubber, and our custom EPDM rubber compound features very good compression set, high tensile strength, excellent weathering, ozone, UV, water, steam, high and low temperature resistance.

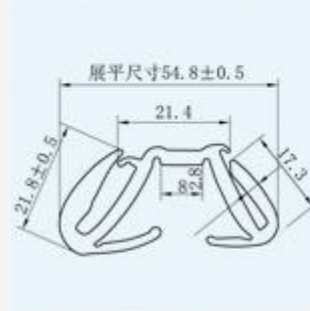
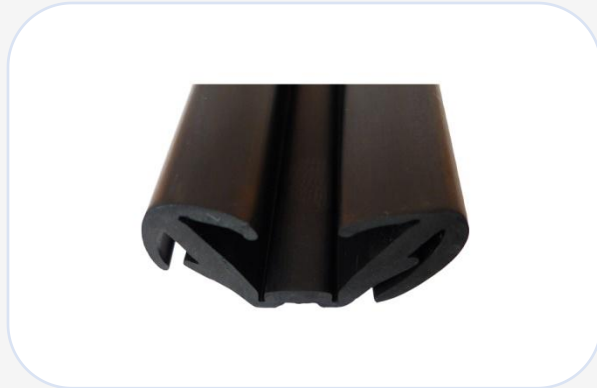

SDQC-009



SDQC-010

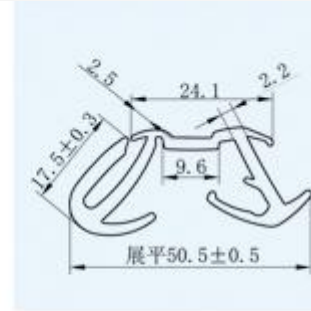

SDQC-011

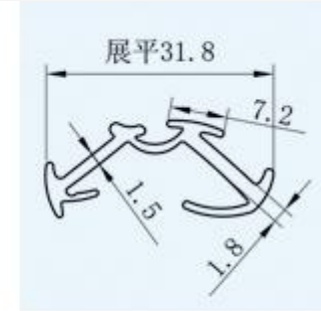

SDQC-012



Standard Weatherstrips - Door Glass Runs / TPV

Thermoplastic Vulcanizates (TPV) are a special class of TPE that contains a cross linked rubber phase dispersed within a thermoplastic polymer phase. TPV compounds are chemically cross linked with PP / EPDM, in which EPDM is dynamically cross linked and dispersed in polypropylene phase. Hebei Shida Seal Group can extrude custom profiles, seals and gaskets from Thermoplastic Vulcanizates (TPV) materials like Santoprene. As a result of its excellent physical properties, TPV is used for manufacturing glass run channels and other static weatherseals at our facility. Our TPV corner moldings offer excellent bond strength and aesthetics.



Standard Weatherstrips - Windshield Seals

Hebei Shida Seal Group manufactures automotive windshield and rear window weatherstrips and seals, one-piece self sealing weatherstrips, two-piece self sealing weatherstrips, window rubber locking gaskets, glass setting channels, auto glass universal moldings for automotive industry. The mostly used material is EPDM rubber, and our custom EPDM rubber compound features very good compression set, high tensile strength, excellent weathering, ozone, UV, water, steam, high and low temperature resistance. (We also provide seal with metal filament).



SDQC-013

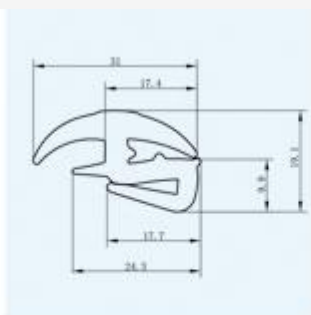

SDQC-014

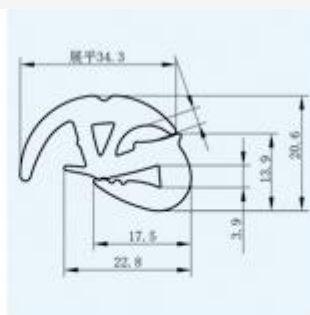

SDQC-015



SDQC-016

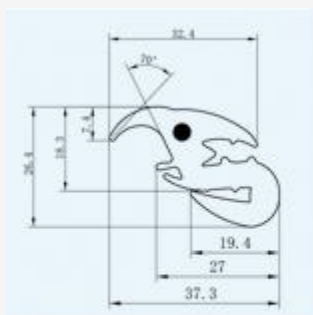

SDQC-017

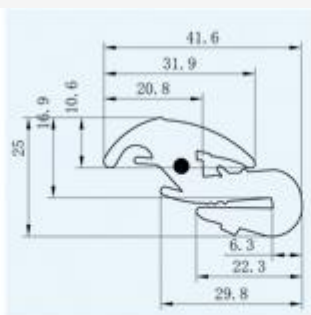

SDQC-018

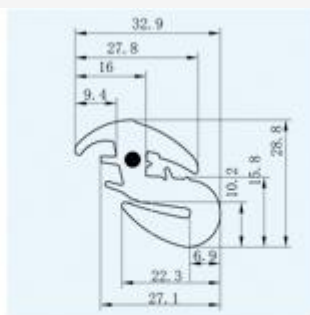

SDQC-019

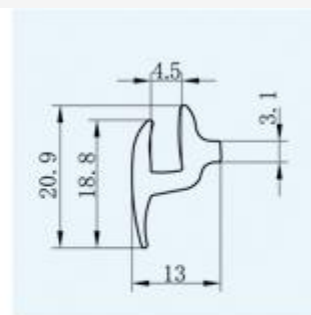

SDQC-020



Standard Weatherstrips - Windshield Seals

Hebei Shida Seal Group manufactures automotive windshield and rear window weatherstrips and seals, one-piece self sealing weatherstrips, two-piece self sealing weatherstrips, window rubber locking gaskets, glass setting channels, auto glass universal moldings for automotive industry. The mostly used material is EPDM rubber, and our custom EPDM rubber compound features very good compression set, high tensile strength, excellent weathering, ozone, UV, water, steam, high and low temperature resistance. (We also provide seal with metal filament).

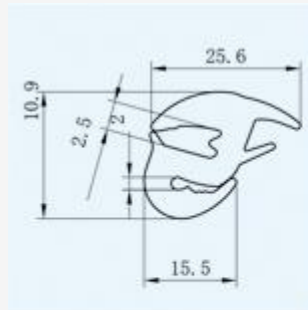
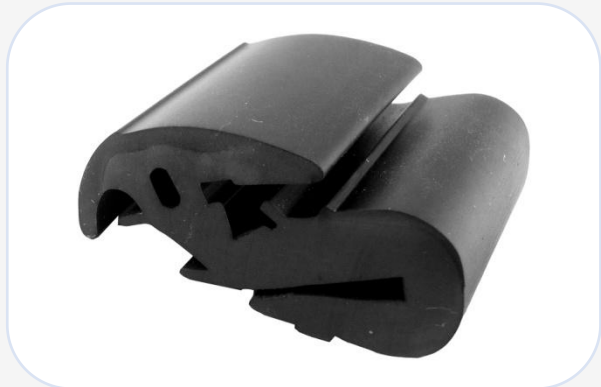

SDQC-021

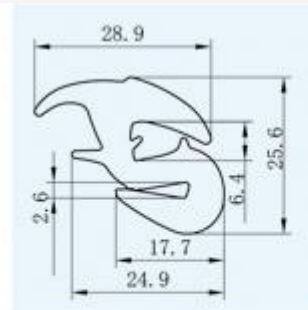

SDQC-022

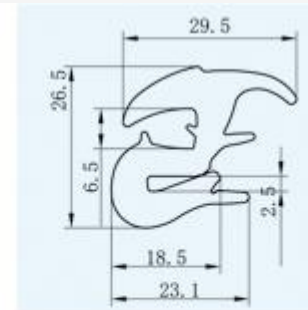

SDQC-023

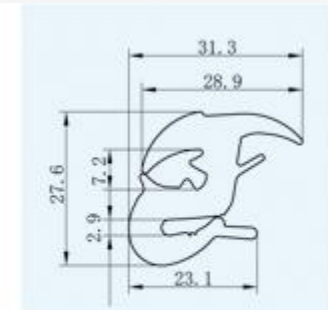

SDQC-024



Standard Weatherstrips - Door Seals / Trunk Seals / Trim Seals

Hebei Shida Seal Group manufactures automotive sealing products – door opening trim weatherstrips, secondary door seals, on-body seals, trunk seals, tailgate seals, deck lid seals for passenger and commercial vehicles. The mostly used material is EPDM dense rubber + EPDM sponge rubber + steel carrier / steel wire carrier, and our custom EPDM rubber compound features very good compression set, high tensile strength, excellent weathering, ozone, UV, water, steam, high and low temperature resistance.



SDQC-025

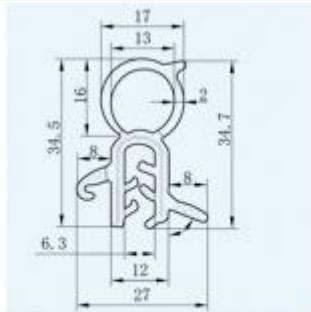

SDQC-026

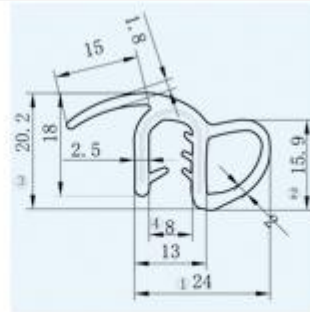

SDQC-027

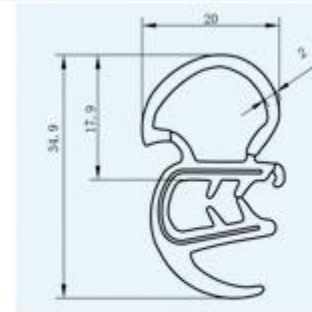

SDQC-028

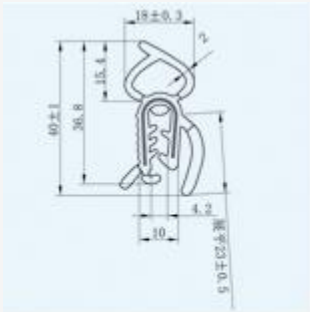

SDQC-029

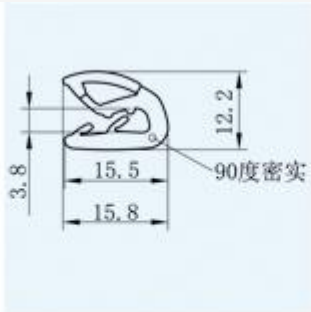

SDQC-030

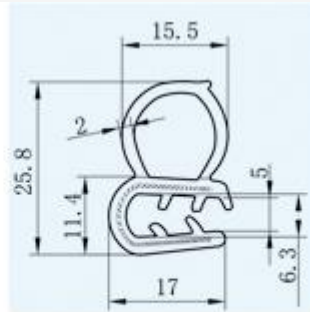

SDQC-031

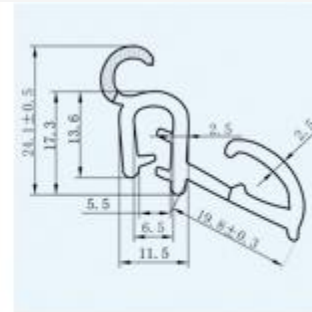

SDQC-032



Standard Weatherstrips - Door Seals / Trunk Seals / Trim Seals

Hebei Shida Seal Group manufactures automotive sealing products – door opening trim weatherstrips, secondary door seals, on-body seals, trunk seals, tailgate seals, deck lid seals for passenger and commercial vehicles. The mostly used material is EPDM dense rubber + EPDM sponge rubber + steel carrier / steel wire carrier, and our custom EPDM rubber compound features very good compression set, high tensile strength, excellent weathering, ozone, UV, water, steam, high and low temperature resistance.

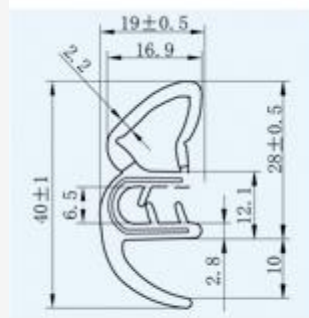

SDQC-033

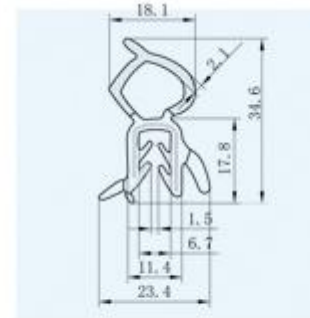

SDQC-034

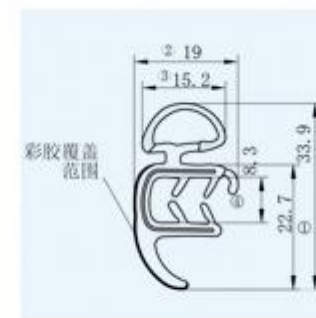

SDQC-035



SDQC-036

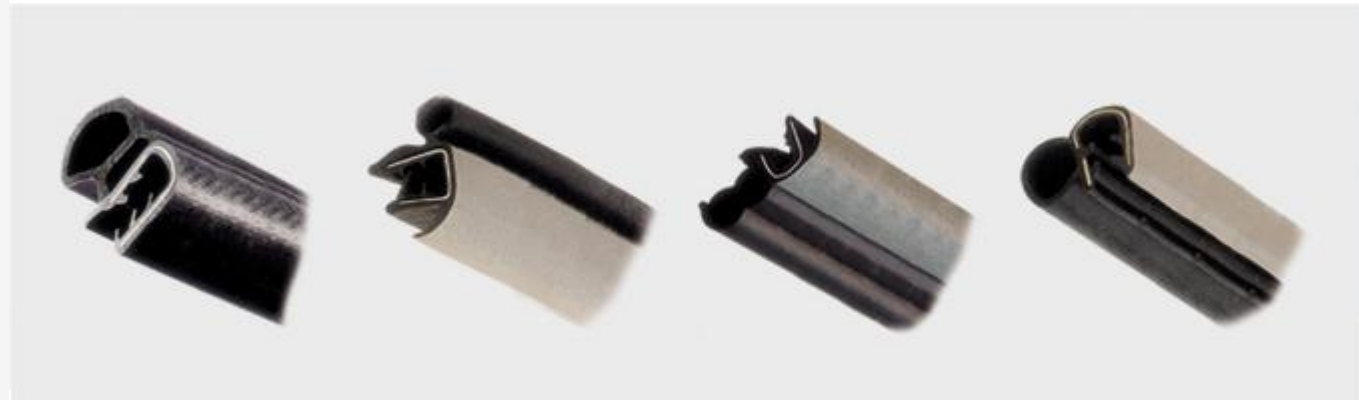

Standard Weatherstrips - On-Door Seals

Hebei Shida Seal Group manufactures automotive sealing products – door weatherstrips, primary door seals with retainers (plastic clips), on-door seals, push-pin seals, door frame rubber profiles for passenger and commercial vehicles. The mostly used material is EPDM sponge rubber and our custom EPDM rubber compound features very good compression set, high tensile strength, excellent weathering, ozone, UV, water, steam, high and low temperature resistance.

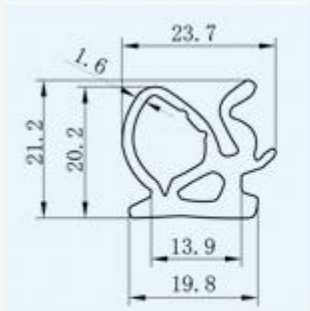

SDQC-037



SDQC-038

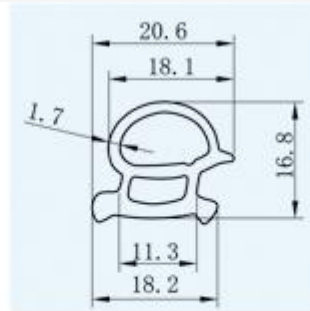

SDQC-039

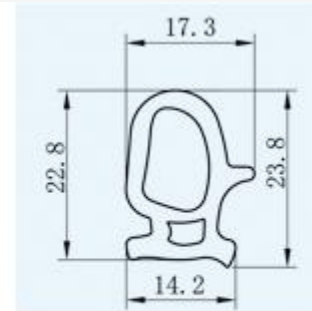

SDQC-040

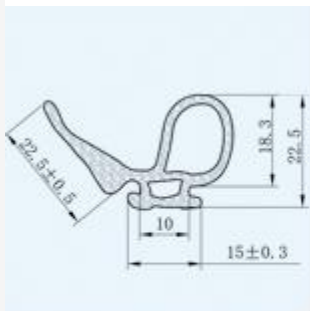

SDQC-041



SDQC-042

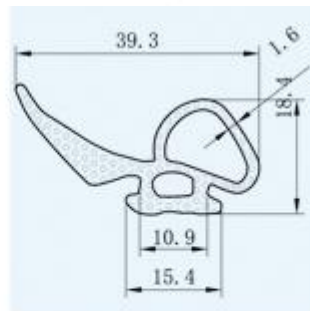

SDQC-043

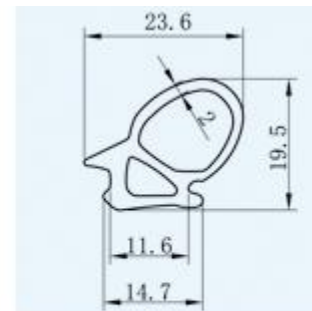

SDQC-044



Standard Weatherstrips - On-Door Seals / Hood Seals

Hebei Shida Seal Group manufactures automotive sealing products – door weatherstrips, primary door seals retainers (plastic clips), on-door seals, push-pin seals, door frame rubber profiles for passenger and commercial vehicles. The mostly used material is EPDM sponge rubber and our custom EPDM rubber compound features very good compression set, high tensile strength, excellent weathering, ozone, UV, water, steam, high and low temperature resistance.

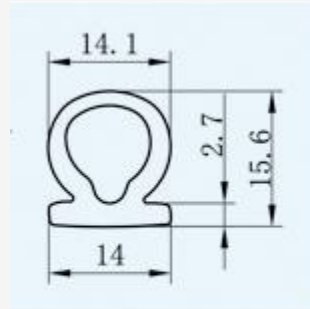
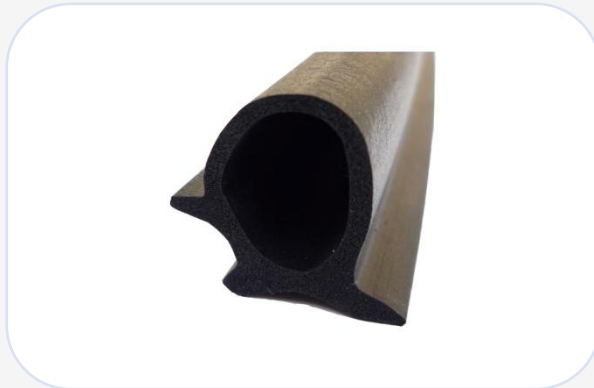

SDQC-045

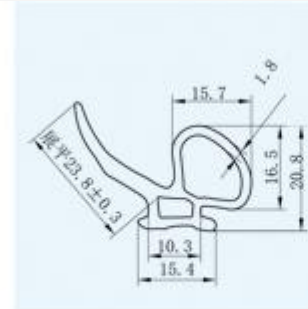

SDQC-046

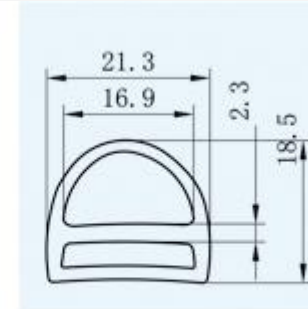

SDQC-047

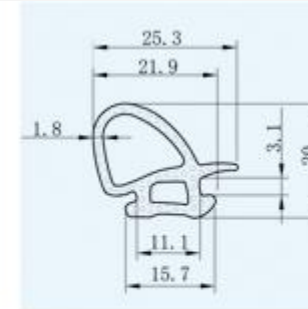

SDQC-048



More Projects - Door Weatherstrips

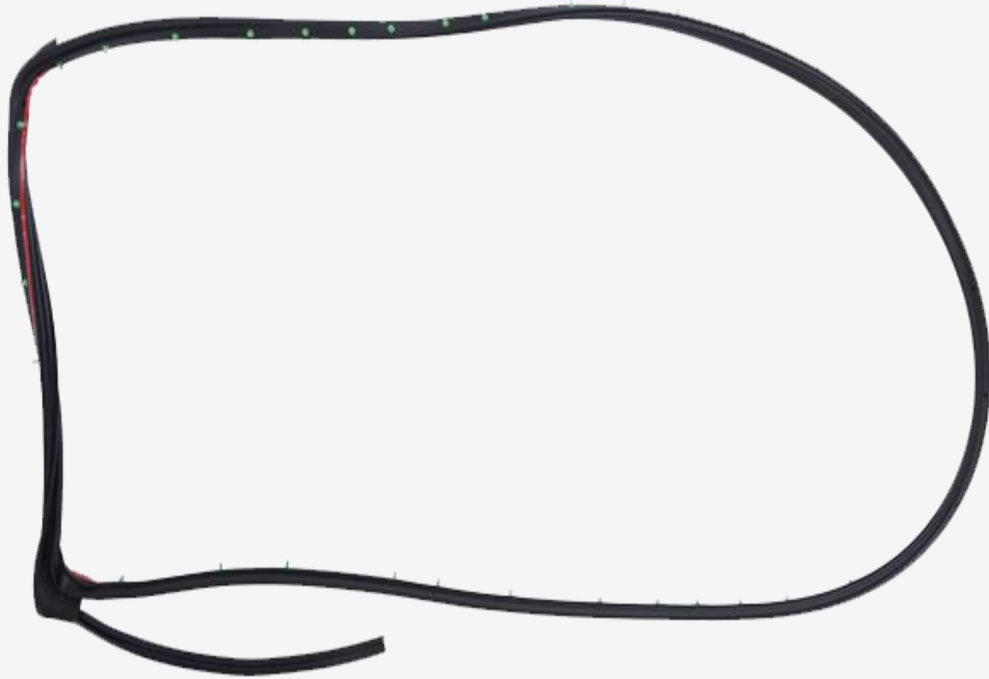

More Projects - Door Opening Weatherstrips



More Projects - Door Opening Weatherstrips



More Projects - Door Glass Run Channel (EPDM)



More Projects - Door Glass Run Channel (TPV)



More Projects - Hood Seals



More Projects – Windshield Molding



More Projects – Windshield Molding



More Projects - Automotive Weatherstrips



More Projects – Power Window Inserts / Gasket for Window Regulator



- ◆ Material: EPDM Dense Rubber
- ◆ Process: Extruding, Cutting
- ◆ Customer: Tier 1 Supplier to Major OEMs

More Projects – Door Lock Bumpers / Hood Bumpers



Material: EPDM Dense Rubber



Process: Extruding, Cutting

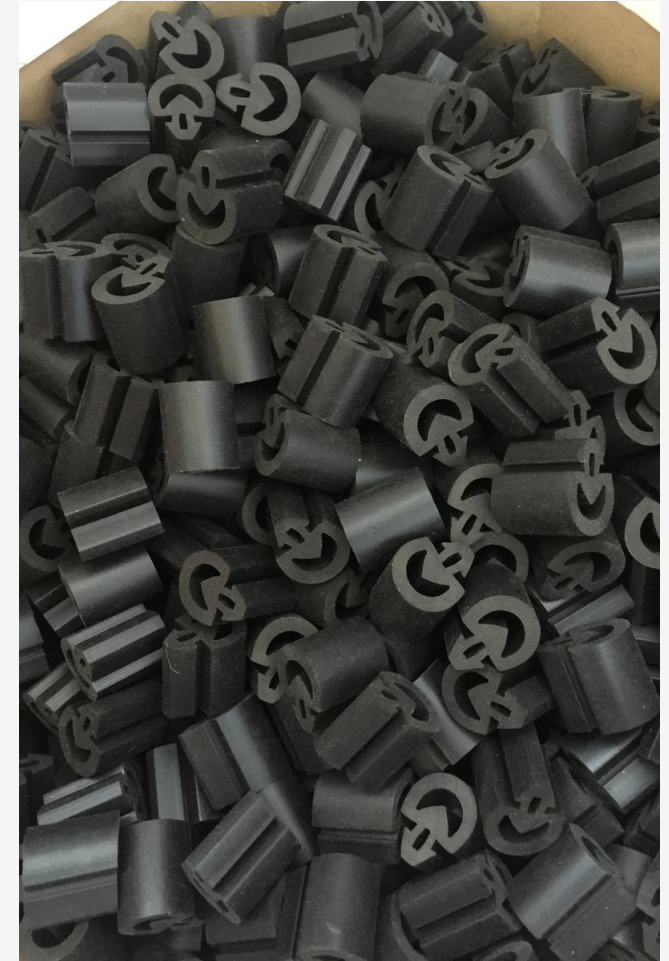

Customer: OEM & Aftermarket

Extruded - Dense Rubber Extrusions

Hebei Shida Seal Group manufactures dense rubber extrusion products in compounds including EPDM, NBR, Silicone rubber and all our extruded rubber products meet or exceed industry specifications. Our dense rubber extrusions comes in different types: u-channels, e-strips, glazing seals, j-seals, p-strips, square and round cords, tubings, strips, locking and self-locking gaskets and channels and are used in markets like automotive and transportation, building and construction, recreational vehicle, appliance, power supply, etc. Custom dense rubber extrusions are available with or without pressure sensitive adhesive (PSA) backing.

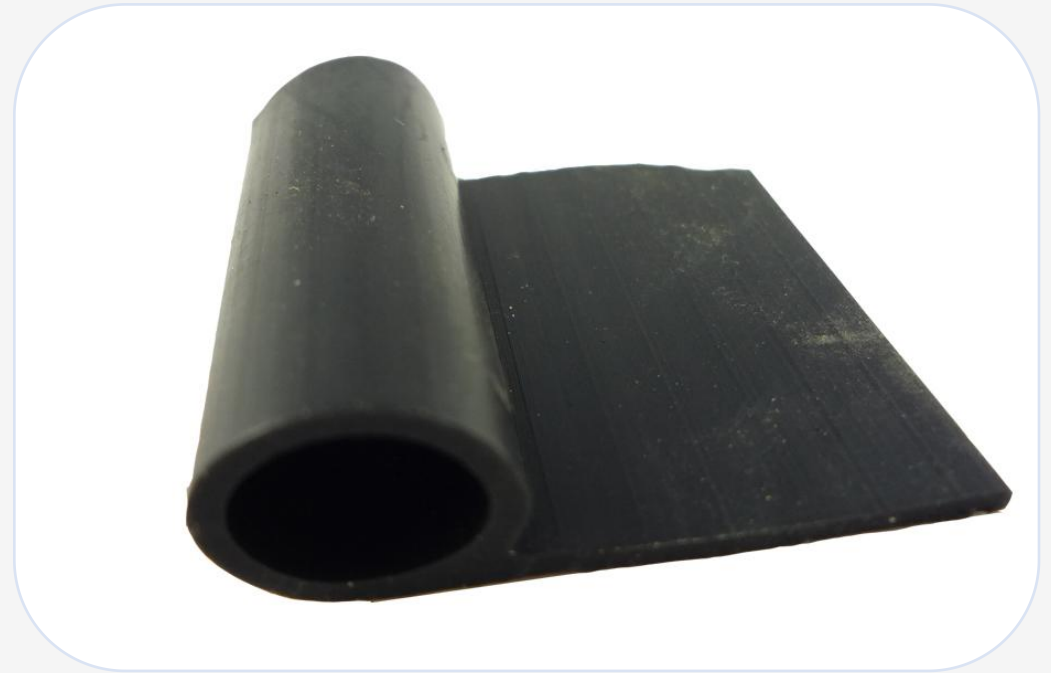

Extruded - Sponge Rubber Extrusions

Hebei Shida Seal Group is a recognized leading manufacturer and supplier of high quality custom sponge rubber extrusions and extruded sponge rubber products. We can fabricate extruded rubber profiles and products in all shapes, sizes and lengths from a wide range of EPDM sponge rubber compounds. Popular profiles and shapes include: circular channel extrusions, d-strip extrusions, e-channel extrusions, h-channel extrusions, l-strip extrusions, p-strip extrusions, t-shape extrusions, u-channel extrusions. Sponge extrusions are used in markets like automotive and transportation, building and construction, recreational vehicle, appliance, power supply, etc. Custom sponge rubber extrusions are available with or without pressure sensitive adhesive (PSA) backing.



Extruded - Dual Durometer Seals

Hebei Shida Seal Group specializes in design, development and manufacture of dual durometer extrusions, extruded dual durometer seals, and industrial rubber seals. Main material is EPDM dense and sponge rubber, which can be extruded into profiles of various shapes and sizes. Our custom EPDM rubber compound features very good compression set, high tensile strength, excellent weathering, ozone, UV, water, steam, high and low temperature resistance. We can supply dual durometer rubber extrusions in continuous lengths or accurately cut to specific lengths if required and we also provide various secondary applications, post-cure processes to our rubber extruding services: including splicing, corner molding, notching, taping, PSA adhesives, etc.

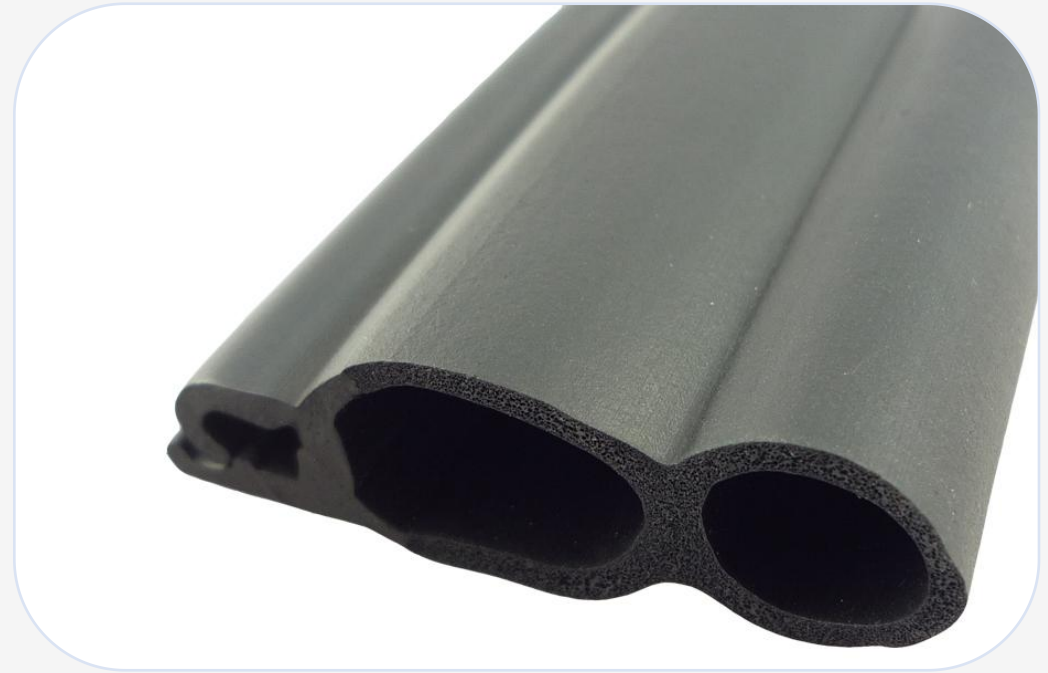
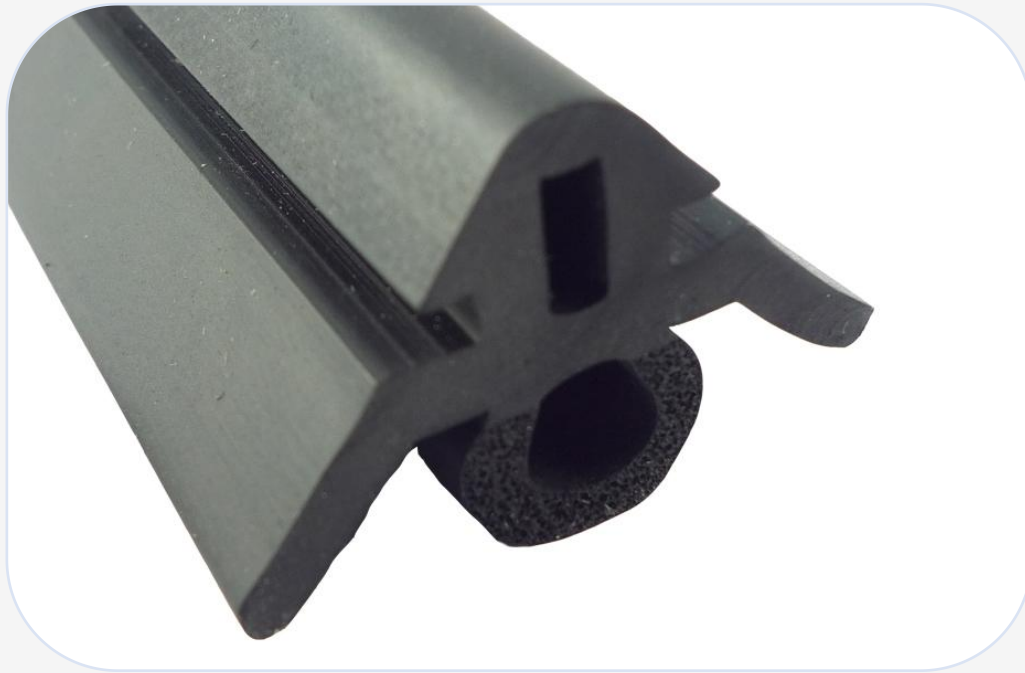

Extruded - PVC Edge Trim

Hebei Shida Seal Group specializes in design, development and manufacture of PVC edge trim, embossed plastic edge trims, vinyl edge protectors, edge trims and seals inner flexible metal insert double lips, PVC edge protectors with steel spring core, PVC edge protector profiles, PVC clamp profiles with steel core, sealing profiles, co-extrusion profiles, edge protection profiles with embedded metal, edge protection seal profiles with steel clamp band, soft PVC edge protection profiles with integrated steel clamp. Main material is Polyvinyl Chloride (PVC), temperature resistant -40 °C to 90 °C, which can be extruded into profiles of various shapes, sizes and colors. Our custom PVC compound features very good compression set, high tensile strength, excellent weathering, ozone, UV, water, steam, high and low temperature resistance.

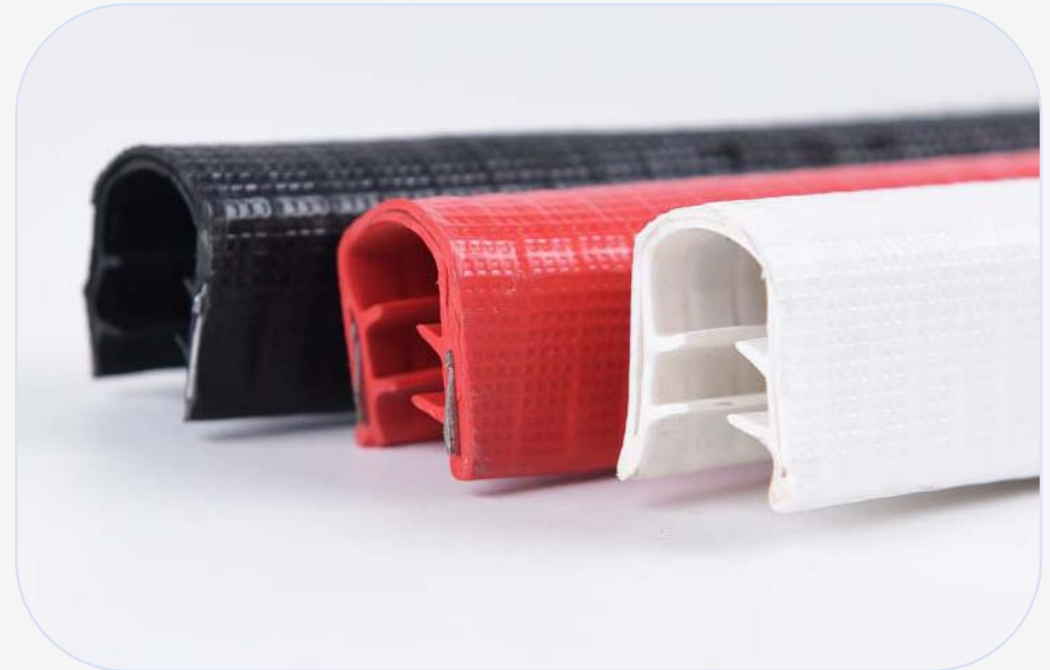

Extruded - Silicone Rubber Extrusions

Hebei Shida Seal Group is a silicone rubber extrusions specialist that delivers custom silicone rubber extruded profiles. Silicone extrusions are available in various profiles to suit your individual requirements. We are able to manufacture most profiles from samples or drawings.

We offers silicone rubber extrusions for more purposes than you could ever

imagine:

- Door seals
- Window seals
- Seals for ships
- Seals for building constructions

Colours available :

- Translucent, White, Black, Grey, Red,
- Green, Yellow, Blue



Extruded - Flame Retardant Rubber Seals

Hebei Shida Seal Group design and manufactures UL Flame Retardant EPDM rubber compounds for a variety of applications. These compounds are available as: spliced and fabricated parts, long length extrusions, and precision extruded and cut seals.

We offer Flame Retardant EPDM rubber compound certified to UL 94 V-0. The UL 94 V-0 testing covers the flammability characteristics of rubber materials.

UL defines the Vertical Burning rate (V0, V1, V2) as the calculation of the vertical burn rate in millimeters per minute.

By passing the most difficult V0 rating, our Flame Retardant EPDM rubber compound also exceeds the requirements for V1, V2, and HB and therefore can be considered in such applications.



Extruded - TPV Extrusions

Hebei Shida Seal Group can extrude custom profiles, seals, and gaskets from thermoplastic vulcanizates (TPV) materials like Santoprene for a variety of markets like construction, automotive, HVAC and OEM markets. From standard profiles to highly intricate shapes, you can rely on our experience to assure that quality parts will be delivered on time and at the right price. Whatever your TPV extrusion application, we can help.

Automotive:

Door Seals

Rocker Panel Seal & Roof Line Seal

Tail Gate Seal, Weatherstrips

Cowl Seal & Hood to Radiator Seal

Glass Run Channels, Weatherseals

HVAC:

Access Door Gaskets

Screw Cover Gasket

Duct/Pipe Seals

Weather-stripping & Gaskets

Edge Guards

Industrial OEM::

Access Door Panel Seal

Dynamic Seal with Mounting Tape and Slipcoat

Spill Containment Seal for Wind Generator

Bearing Block



Extruded - Heater Hoses

Hebei Shida Seal Group specializes in the design and manufacture of heater hoses for a wide range of industries. All hoses and tooling is produced in our internal facility accredited to TS 16949 with full engineering, testing and CAD capability. Our heater Hose is formulated from rubber compounds developed for Original Equipment (OE) applications and is suitable for plain water and automotive coolant applications.

Construction & Specifications:

Tube: High quality EPDM rubber

Reinforcement: High tensile synthetic textile (Knitted PET)

Cover: High quality EPDM rubber

Hose Type: SAE J20 R3—Heater hose for normal service.

Hose Class: Class D-2—low oil resistant, standard service

Temperature Range: -40°C to +125°C (-40°F to 257°F)

CAUTION: Not suitable for fuel, oil or brake fluid applications.



Extruded - Silicone Heater Hoses

Silicone heater hose is used for the high demands of the engine compartment of automobiles & large diesel trucks to off road heavy equipment and power generators! Our silicone heater hoses meet or exceed the requirements of the SAE J20 R3 Class A specification.

Features and Benefits:

- Resistant to a wide range of temperatures
- Resistant to hardening, cracking, ozone attack, sunlight
- Resistant to moisture, steam, dust, aging, various pressure ranges
- Resistant to many chemicals
- Retains flexibility in hostile engine environments
- Excellent electrical insulating properties
- Longer life than EPDM (Black Rubber)

Technical Details::

- Reinforcement: 1-ply polyester fabric
- Colors: Red, blue, yellow, black, green, etc.
- Temperature Range: – 60 °C to + 180 °C (-76°F ~ +356°F)



Extruded - Fuel & Oil Hoses

Our fuel and oil Hose is developed using materials from our experience as an Original Equipment Manufacturer (OEM). The hose is suitable for low pressure fuel use with leaded and unleaded petrol, Ethanol blended fuels up to E85, Diesel & Biodiesel fuels, lubricating oil as well as crankcase and fuel vapour.

Construction & Specifications:

Tube: High quality Nitrile (NBR)

Reinforcement: High tensile synthetic textile (Knitted PET)

Cover: Oil resistant Nitrile/PVC (NBR/PVC) blended rubber

Hose Type: SAE 30 R6

Temperature Range: -40°C to +125°C (-40°F to 257°F)

CAUTION: Not suitable for fuel injection, in-tank fuel submersion, coolant transfer, brake fluid or marine applications.



Molded Rubber Products - Wiring Harness Grommets

Hebei Shida Seal Group can manufacture a wide spectrum of molded rubber parts like wiring harness grommets, wiring harness door rubber grommets, ABS wiring grommets, dumbbell grommets, wire harness grommets and rubber grommets used to protect an automotive wiring harness passing through an aperture in a metal structure of a vehicle. The mostly used material is EPDM dense rubber and our custom EPDM rubber compound features very good compression set, high tensile strength, excellent weathering, ozone, UV, water, steam, high and low temperature resistance. Most grommets are molded entirely from rubber while others are a hybrid of rubber and metal materials. Our wiring harness grommets are used for manufacturing automobiles, commercial trucks and agriculture vehicles.



Molded Rubber Products - Rubber Pedal Pads

Hebei Shida Seal Group specializes in the manufacturing and molding of custom rubber products. Parts include: molded rubber pedals and pedal pads, after market pedal pads, rubber step pads, brake pedal pads, clutch pedal pads, accelerator pedal pad, replacement rubber pads, brake pedal cover, parking brake pedal pads. Our rubber pedal pads are made of high-quality EPDM (Ethylene Propylene Diene Monomer) rubber compound and are used for manufacturing automobiles, commercial trucks and agriculture vehicles.

Why Choose Hebei Shida Seal Group?

- ✓ Low tooling costs.
- ✓ Press sizes range from 50 ton to 300 ton.
- ✓ Excel in both simple and complex projects.
- ✓ Supply in both high and low volume quantities.
- ✓ Capabilities to supply PPAP and process control documentation.
- ✓ In-house custom compound formulating, and mixing capabilities.
- ✓ Efficient, cost-effective manufacturing in ISO/TS 16949 certified facility.
- ✓ Compression Molding or Injection Molding



Molded Rubber Products - Air Intake Hoses

Hebei Shida Seal Group can manufacture a variety of molded rubber parts in air intake systems of automobiles, commercial trucks and agriculture vehicles. An air intake hose is a cylindrical piece of rubber that connects the air filter box and the intake manifold. Our air intake hoses can meet the exacting specifications of your air intake system..

Features of Our Molded Rubber Air Intake Hoses:

- ✓ Reduce noise level and vibration
- ✓ Resist tears and punctures
- ✓ Won't harden from exposure to extreme operating temperatures or weather
- ✓ Compression molded or injection molded



Molded Rubber Products - Rubber Bellows and Convoluted Boots

Hebei Shida Seal Group specializes in custom molded rubber parts used for manufacturing control cables/bowden cables/mechanical cable assemblies installed on brake systems, door and hood opening systems, seat shifting systems, window regulators of automobiles, commercial trucks and agriculture vehicles.

Rubber Bellows	Rubber Gaiters	Rubber Boots & Dust Covers	Rubber Corrugated Sleeve
Rubber Cable Cover Bellow	Flexible Moulded Bellows	Rubber Parts for Cables	Cable Covers & Convoluted Boots
Protective Cover Bellows	Bowden Cable Rubber Boot	Clutch Cable Rubber Boot	Mechanical Control Cable Accessories



Customers

Hebei Shida Seal Group works closely with our partners to design, manufacture and supply standard and custom automotive weatherstripping, weather strips, rubber and plastic seals, extruded and molded rubber products. Our dedication to customer satisfaction help us develop a strong customer base including Automotive OEM' and tier 1 suppliers.



Manufacturing Facility Tour

Modern State-Of-The-Art Facility For Rubber Extrusions and Secondary Operations, Located in Qinghe, Hebei, China

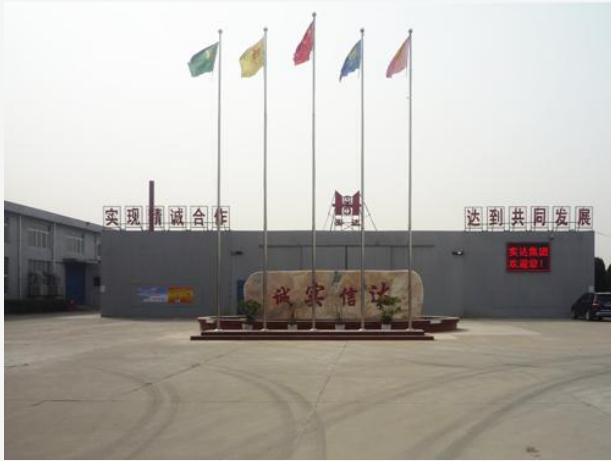

Manufacturing Facility Tour

Modern State-Of-The-Art Facility For Molded Rubber Products, Located in Qinghe, Hebei, China



Logistics

Hebei Shida Seal Group exports its extruded and molded rubber products to customers around the world. Working with our freight forwarder and its wide network of global partners, we can ship cargo globally by ocean and air freight. Our preferred method for international shipping ((INCOTERM): Ex-Works, FCA, FOB, CIF.



Our Location in Hebei, China



Sea Freight

From:

The Port of Tianjin
(Tianjin Xingang)



Air Freight

From:

Beijing Capital
International Airport

Contact Us

Hebei Shida Seal Group Co., Ltd. (河北实达密封件集团有限公司)

Ken Song General Manager

Add: No. 8, Xihuan Road, Wangguanzhuang, Qinghe, Hebei, China

Kevin Feng Sales Director

Tel: +86-319-8032 626

Fax: +86-319-8138 918

Email: shida@shidarubber.com

Website: www.shidarubber.com

www.shidaseal.com



shida@shidaseal.com